



ZORZINI S.p.a.



ZORZINI S.p.a.

# Addendum to the general instructions manual Zorzini oval manwaydoors type 190 - 191





ZORZINI S.p.a.

rev.01 08-07-14

# WELDING SYSTEM

1 Zorzini Spa checks the correct coupling of lid and frame of each single product before the shipment.

Therefore eventual deformation of the frame occurred after the installation and the resulting problems will not be object of the guarantee.

2 Fix the frame to the tank through welding spots as in the picture, and move to the continuous welding along the perimeter just after that.

3 In order to avoid the overheating and the consequent deformation of the frame, we suggest to weld with the TIG method (UNI ISO 287-1)

## FIXING WELDING SPOTS:

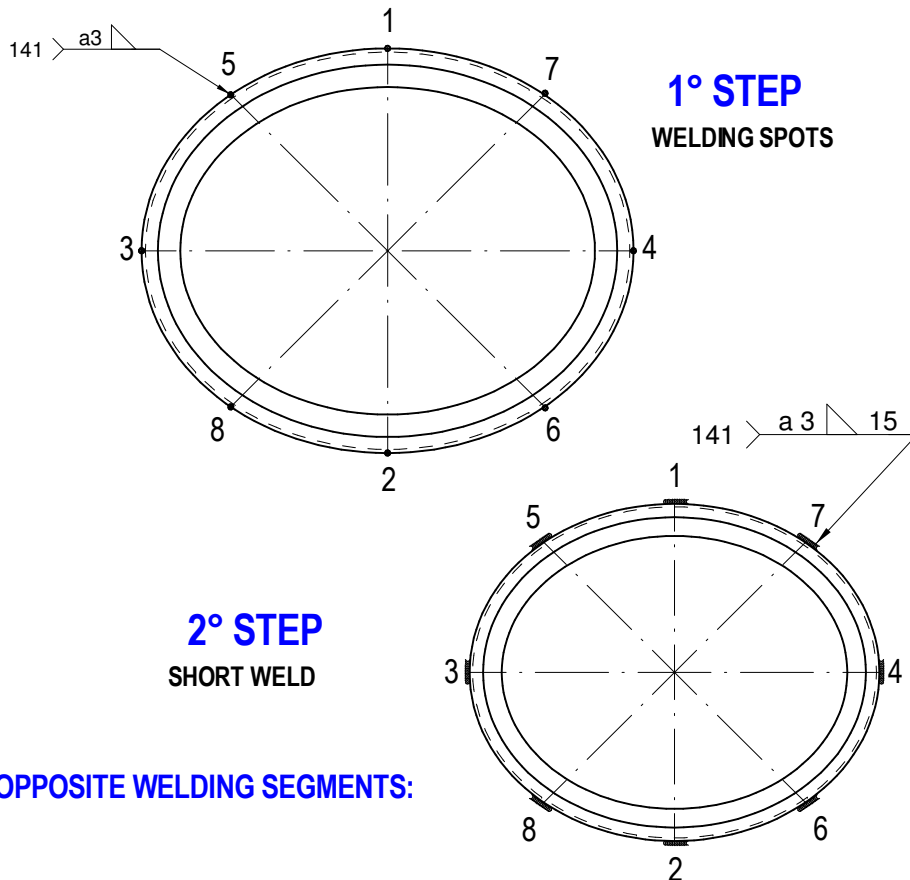

## OPPOSITE WELDING SEGMENTS:



ZORZINI S.p.a.

rev.01 08-07-14

4 After welding please check the flatness.

